



16" RIDE-ON CYCLE

Ages 3-8
Weight limit 70 lbs. (31.8kg)
INSTRUCTIONS Ver. 4

For further assembly assistance visit:
www.originalbigwheel.com
click on 'Assembly Help'

For Replacement Parts or Customer Service Assistance
CONTACT US AT OUR WEB SITE AT:
www.gamma2.net

OR CALL: 1-800-842-6543
Alpha International, Inc. & Gamma² Inc.

NAME	AMOUNT
A- Body	1
B- Seat	1
C- Front Wheel	1
D- Rear Wheel	2
E- Handlebars	1
F- Front Fork	1
G- Pedal	2
H- Rear Axle	1
I- Pedal Crank	1
J- Wheel Insert (halves)	4
K- Capnut Tool	1
L- Fork Block	2
M- Capnut	2
N- Washer	2
O- 5/8" Screw	2
P- 1" Screw	2
Q- 1 3/4" Screw	2

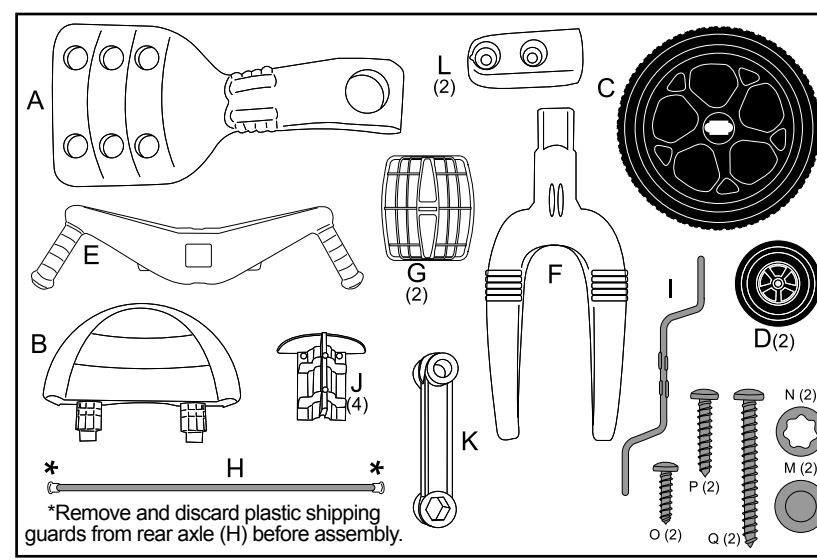

*Remove and discard plastic shipping guards from rear axle (H) before assembly.

PLEASE RETAIN THIS INSTRUCTION GUIDE FOR FUTURE REFERENCE.
Please note...This product should be assembled by an adult. Periodically check all hardware to be certain that it is secure. Instructions should be read thoroughly prior to assembly. Refer to parts list of the instructions to familiarize yourself with the parts and terminology of the component parts. Read each step and do them in the order they are shown.

CAUTION: ADULT SUPERVISION AND INSTRUCTION IS REQUIRED FOR THE PROPER USE OF THIS CYCLE. THIS CYCLE SHOULD NOT BE RIDDEN AROUND SWIMMING POOLS, NEAR HILLS, ROADS OR HIGHWAYS, SLOPED DRIVEWAYS, ALLEYS OR STEPS. RIDERS ARE TO WEAR SHOES AT ALL TIMES. ONLY ONE RIDER AT A TIME. PRIOR TO ASSEMBLY, SMALL PARTS MAY BE HAZARDOUS TO CHILDREN UNDER 3 YEARS OF AGE. CARE SHOULD BE TAKEN IN THE UNPACKING AND ASSEMBLY OF THE TOY. ALWAYS WEAR A HELMET.

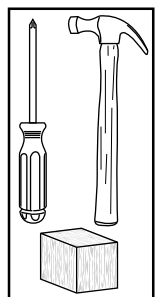

Tools Required (Not Included)
Hammer
Phillips®
Screwdriver
Small wood block

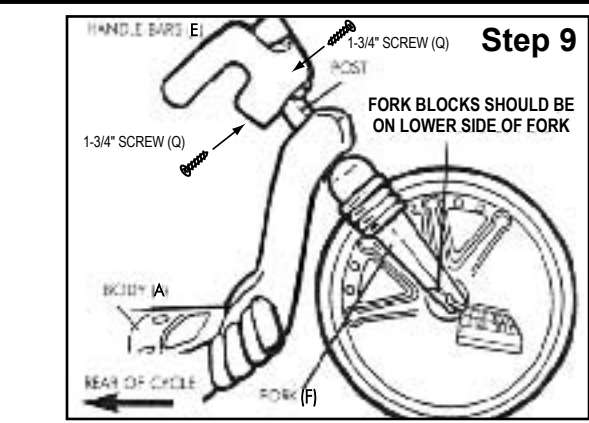
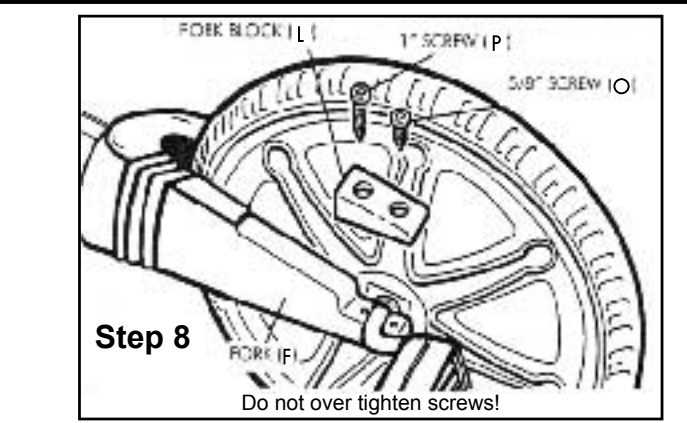
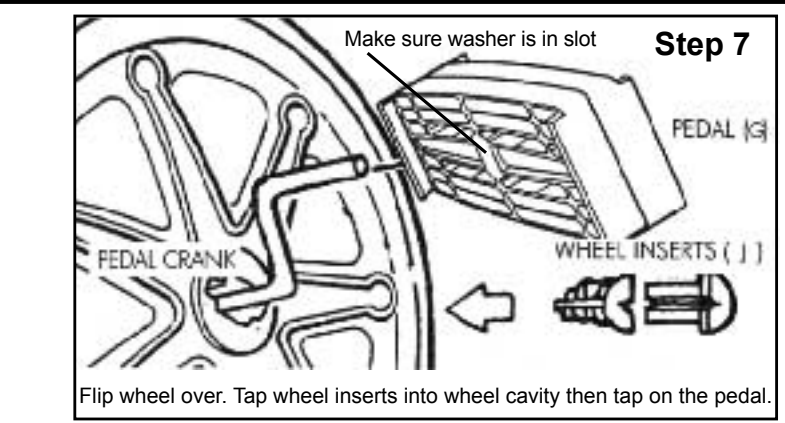
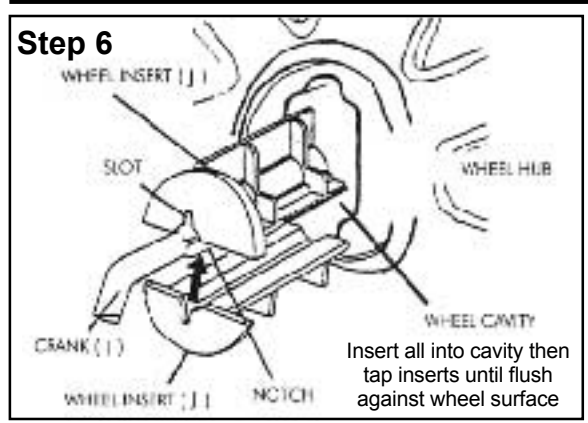
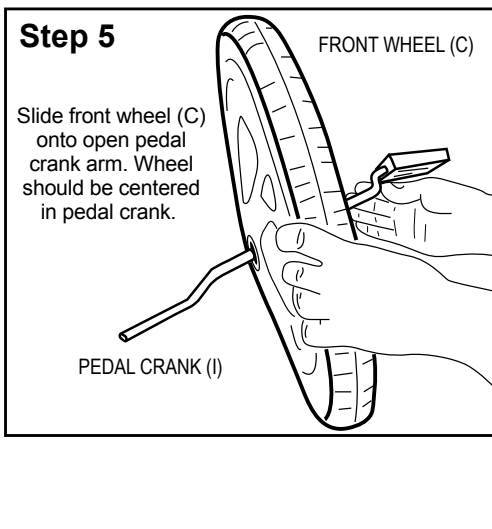
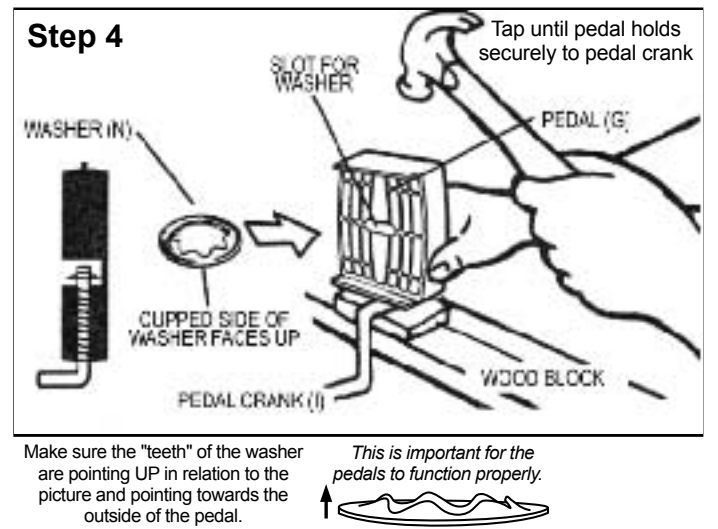
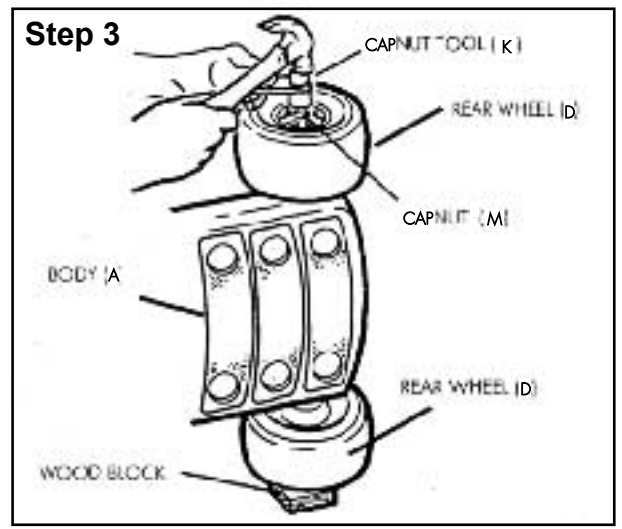
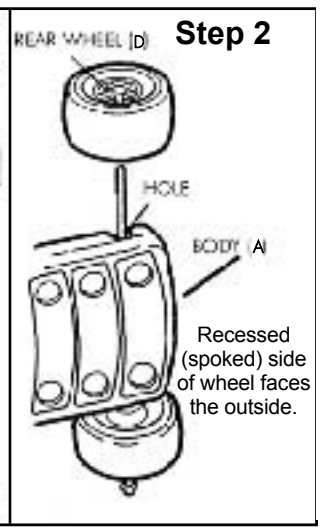
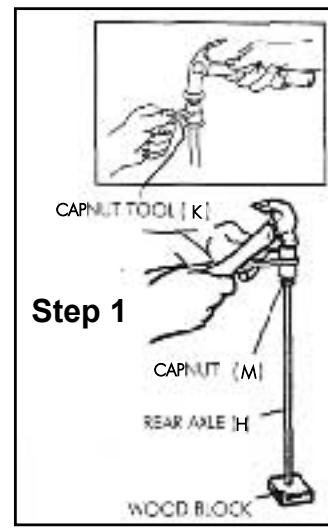

Decal View

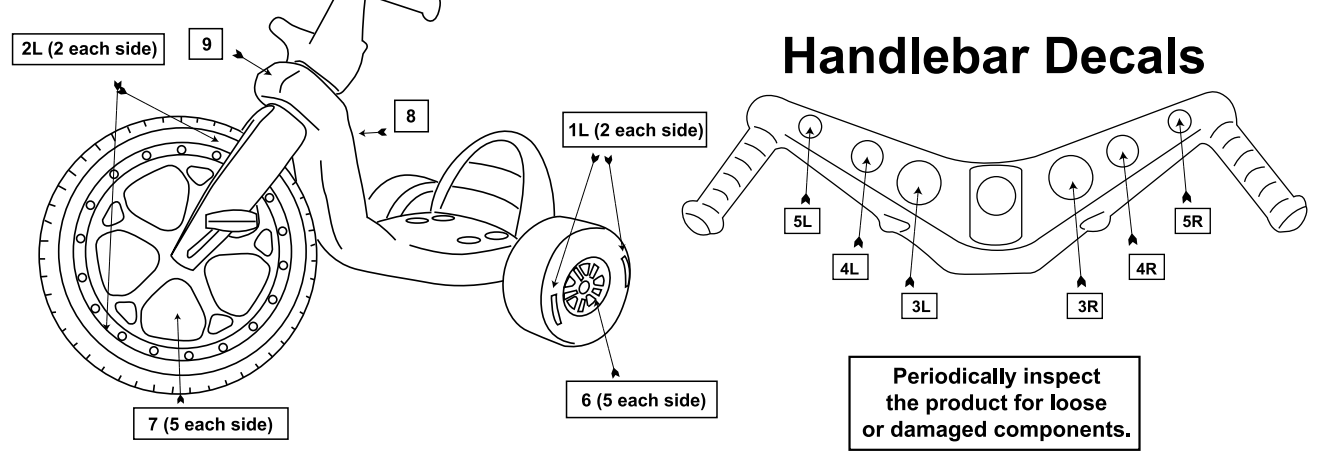

Handlebar Decals

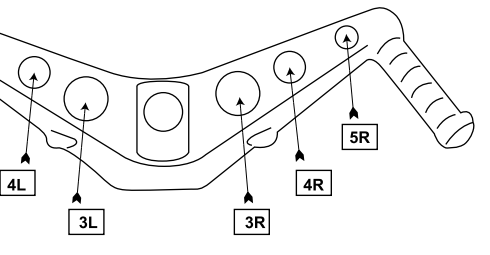

Periodically inspect the product for loose or damaged components.

LIMITED 30 DAY WARRANTY

Alpha International, Inc. warrants this item to be free from manufacturer's defects in material and workmanship for 30 days from the original date of purchase. If a defect exists, at its option, Alpha International, Inc. will either repair or replace the product, free of charge. You are responsible for the cost of returning the product to the manufacturer, Gamma² Incorporated.

This Limited Warranty does not cover any damage due to 1) abuse of this product in any manner beyond its intended use; 2) normal wear and tear and 3) fading due to the harsh effects of prolonged sunlight. This Limited Warranty is non-transferable.

THIS LIMITED WARRANTY AND THE REMEDIES SET FORTH ABOVE ARE EXCLUSIVE AND IN LIEU OF ALL OTHER WARRANTIES, REMEDIES AND CONDITIONS, WHETHER ORAL OR WRITTEN, EXPRESS OR IMPLIED. ALPHA INTERNATIONAL, INC. SPECIFICALLY DISCLAIMS ANY AND ALL IMPLIED WARRANTIES, INCLUDING, WITHOUT LIMITATION, WARRANTIES OF MERCHANTABILITY AND/OR FITNESS FOR A PARTICULAR PURPOSE. IF ALPHA INTERNATIONAL, INC. CANNOT LAWFULLY DISCLAIM IMPLIED WARRANTIES UNDER THIS LIMITED WARRANTY, ALL SUCH WARRANTIES, INCLUDING WARRANTIES OF MERCHANTABILITY AND FITNESS FOR A PARTICULAR PURPOSE ARE LIMITED IN DURATION TO THE DURATION OF THIS WARRANTY.

ALPHA INTERNATIONAL, INC. SHALL NOT BE LIABLE OR RESPONSIBLE FOR ANY DIRECT, SPECIAL, INCIDENTAL OR CONSEQUENTIAL DAMAGES RESULTING FROM ANY BREACH OF WARRANTY OR CONDITION, OR UNDER ANY OTHER LEGAL THEORY, INCLUDING BUT NOT LIMITED TO, LOSS OF USE OF THE PRODUCT, BREACH OF CONTRACT, NEGLIGENCE, STRICT LIABILITY OR ANY OTHER LEGAL THEORY RELATED TO THIS PRODUCT.

Some states do not allow the exclusion or limitation of incidental or consequential damages, or allow limitations on how long an implied warranty lasts, so the above warranty limitations or exclusions may not apply to you. This Limited Warranty gives you specific rights, and you may have other rights which vary from state to state.

In order to obtain warranty service for this product in accordance with the terms outlined above, you must contact Gamma² Incorporated at our web site at: www.gamma2.net or call: 1-800-842-6543. Proof of purchase is needed to redeem warranty.